

980 Ionized Air Gun Installation, Operation and Maintenance



Figure 1. SCS 980 Ionized Air Gun

Description

The SCS 980 Ionized Air Gun provides efficient static charge neutralization by effectively removing particle contamination even on some of the most static-sensitive products. The 980 Ionized Air Gun operates from 120VAC power, and the 980E Ionized Air Gun from 230VAC power. All references to model 980 throughout this user's guide pertain to both of the models, unless otherwise noted.

Proprietary technology provides constantly balanced ionization for consistent control of surface charges. The 980 Ionized Air Gun virtually never needs adjustment and requires very little maintenance.

Compact and lightweight, the console for the 980 Ionized Air Gun can be mounted almost anywhere on the workstation for easy access. It connects to a supply of clean, dry air or nitrogen, and an internal disposable filter collects particles from the air supply. The electrical feed from the console to the 980 Ionized Air Gun is incorporated into the light, flexible air hose. The 980 Ionized Air Gun itself is very lightweight and ergonomically designed for long-term user comfort and efficient operation. The console, 980 Ionized Air Gun, and air hose are all designed to be static-dissipative and ESD-safe.

Performance

The 980 Ionized Air Gun helps reduce a static charge of $\pm 1000V$ to $\pm 100V$ in less than 1 second at a distance of 6 inches (15 cm) and 30 psi (2 bars) inlet pressure

when tested in accordance with the ESD Association ionization standard ANSI/ESD-S3.1. Balance variance is within ± 30 volts of zero at a distance of 6 inches (15 cm).

Power Requirements

The 980 Ionized Air Gun console requires 24VAC power, which is provided by the transformer supplied with the unit. A 120VAC transformer is supplied with the 980 Ionized Air Gun, and 230VAC unit is supplied with the 980E Ionized Air Gun.

The SCS Ionized Air Gun is available in the following models:

Item	Voltage
980	120V
980E	230V

Air Supply Requirements

For maximized operation, the SCS 980 Ionized Air Gun should be supplied with clean, dry air, or nitrogen.

Please note that the failure to use clean, dry air or nitrogen may result in damage to the 980 Ionized Air Gun that will not be covered by warranty.

Installation

Choose a location convenient to the work area and to the air supply. The console takes up very little space and is adaptable to a variety of permanent or nonpermanent installations. To minimize bends in the 980 Ionized Air Gun hose, orient the console so that the open end that accepts the filtered air hose to the hand unit points toward the work area, and the male connector points toward the air supply.

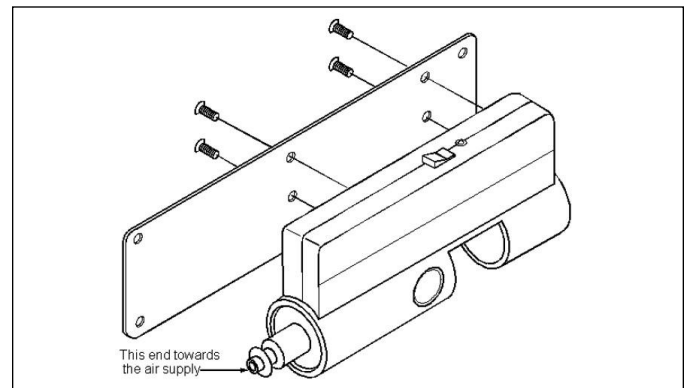

Figure 2. Installing the 980 Ionized Air Gun

Mounting the Console

Prior to mounting, plug the end of the 10-foot (3 m) RJ-11 cable from the power supply into the jack on the back of the console. Lay the cable inside the groove inside the console. Mount the console using the instructions below.

Permanent Mounting

Attach the supplied mounting plate to the threaded holes on the back of the console, using the supplied screws. See Figure 2. Attach the plate to a flat surface, such as a wall or back of a workbench, using suitable screws and fasteners. When mounting to a hollow wall, be sure to use adequate screws and wall anchors to ensure stability of installation.

Non-permanent Mounting

Use SCS Dual Lock Fastener Strips or pads to attach the console to a flat surface.

Mounting onto an Air Supply

When an air supply is close to the work area and fitted with a U.S.- standard industrial interchange quick coupling, you can attach the console to the air supply fitting directly using the female quick coupler provided with the console. If a U.S.-standard industrial interchange quick change is not available on the air supply, be sure to use a suitable interconnect between the air supply and the console, including a prefilter.

CAUTION: Protect the hose from sharp objects, abrasion, and high temperatures. Do not pull or pinch the hose while assembling the components.

Assembling the Components

Insert the larger end of the filter cartridge into the fitting at the end of the flexible air hose. Push the filter gently until it is firmly seated and the metal Filter Release Tab pops out, locking the filter into place.

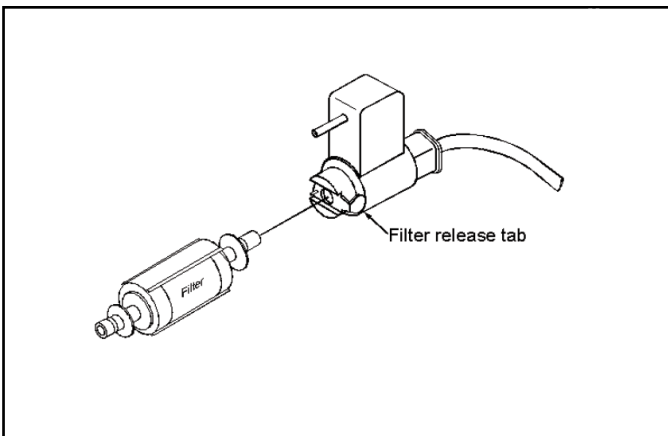

Figure 3. Replacing/Installing filter cartridge

Connect the hose and filter to the console. First, push the Filter Release Button in all the way. Then, push the fitting containing the filter all the way into the opening in the console until it latches with a click. The fitting fits only in the correct orientation. The small plastic fitting on the end of the filter must align with the metal guide coupling in the console. You may have to wiggle the filter slightly while inserting it.

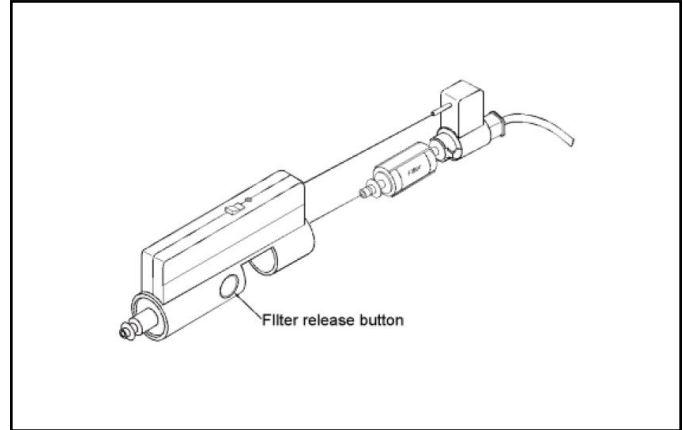

Figure 4. Connecting the hose and filter to console

Connect the male (air inlet) fitting on the console to the air supply. The console is designed for a U.S.-standard, industrial interchange quick coupling. You can attach the console directly to the air supply using the female quick coupler provided with the console, or attach it using a hose (not supplied) or some other interconnect. In both cases, use a prefilter.

Operation

Make sure the Power Switch on the top of the console is in the OFF position. Insert the power cord to the transformer into a properly grounded 120VAC (for 980 Ionized Air Gun) or 230VAC (for 980E Ionized Air Gun) receptacle. Use only the correct transformer, as use of an incorrect wall transformer may result in damage to the unit. Doing so will void the warranty.

Secure the power cord so that it cannot accidentally pull the console and 980 Ionized Air Gun off the workbench.

For safety and the most efficient ionization, set the pressure regulator on your air or nitrogen supply between 20-65 psi (1.4 - 4.5 bars). Discharge times vary depending on air pressure.

NOTE: Pressures of 30-40 psi (2.0-2.8 bars) are commonly used for decontaminating surfaces. Please refer to the pertinent regulations concerning maximum air pressure on hand-held air blow devices in order to determine a safe operating pressure.

The unit is rated at 65 psi (4.5 bars) inlet pressure, at temperatures up to 75° F (24° C), and the rating decreases at higher temperatures. When using high pressures, consider the ambient room temperature as well as heat from surrounding equipment.

Verify that the 980 Ionized Air Gun trigger is not depressed. Turn the power switch on the console to ON. The green LED on the console should illuminate.

Hold the SCS 980 Ionized Air Gun approximately 6 inches (15 cm) from the surface you want to discharge and blow off. Aim the 980 Ionized Air Gun and press the trigger to blow ionized air. The green LED on the back of the 980 Ionized Air Gun lights up while you press the trigger, indicating that the 980 Ionized Air Gun is ionizing. Typically, static electricity on a surface will be discharged within one second. Release the trigger when the surface is assumed to be clean.

If the 980 Ionized Air Gun is not in use, it is recommended that the Power Switch on the console be turned off. This will avoid unintentional operation of the 980 Ionized Air Gun. The included S-hook may be used to hang the 980 Ionized Air Gun out of the way but still within reach.

WARNING: The SCS 980/980E Ionized Air Gun is NOT for use in hazardous environments where the possibility of explosion exists.

Maintenance

The 980/980E Ionized Air Gun requires very little maintenance. Occasional cleaning of the case and emitter points, and periodic replacement of the air filter are all that is required. Always be sure to protect all components from liquids and corrosive chemicals. Carefully follow these maintenance instructions.

CAUTION: Always disconnect power and air supplies before cleaning or replacing components.

Cleaning the Components

Using a cloth moistened with isopropyl alcohol, wipe the exterior surfaces of the console and 980 Ionized Air Gun to remove any dirt or dust that may have collected.

Using a swab moistened with isopropyl alcohol, gently clean the emitter points on the 980 Ionized Air Gun. Extremely dirty emitter points will increase the time needed to discharge static.

Replacing the Air Filter

SCS recommends changing the filter every three months or when it begins to look dirty. Replacement filters are available from SCS (Refer to the table on Page 4).

Hold down the filter release button on the side of the console.

Remove the hose and filter from the console by pulling the textured rubber plug where the hose emerges from the console. Rocking the plug back and forth can help loosen the filter. Do not pull the hose itself. Remove the filter from the hose fitting by depressing the metal release tab on the fitting and pulling the filter.

To install the new filter, follow the directions described previously under "Assembling the Components" on page 2.

Replacing the Emitter Points

The emitter points, built into the plastic tip of the 980 Ionized Air Gun, usually last the life of the unit. However, the tip should be replaced if it is broken, or if the points are bent, broken, otherwise damaged, or if you are unable to remove dirt by cleaning the points with isopropyl alcohol. A replacement tip containing a pair of emitter points is available from SCS.

Insert the tip of a screwdriver into the slot on the SCS 980 Ionized Air Gun barrel.

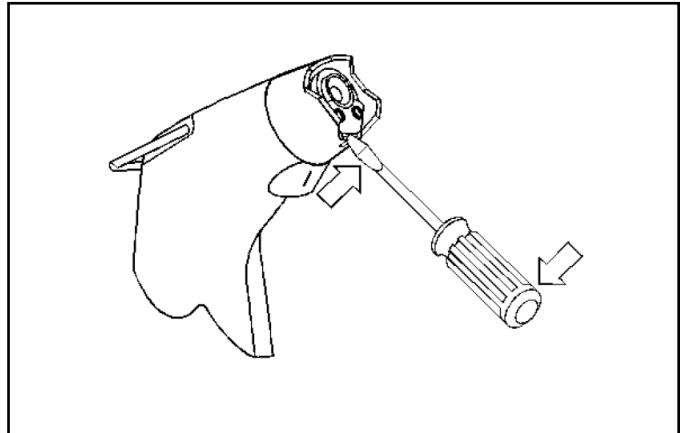

Figure 4. Replacing emitter points

Using the screwdriver as a lever, loosen the old clip, grasp it between your thumb and forefinger, and detach it from the 980 Ionized Air Gun. The emitter points are very sharp; touch only the plastic lip, and handle it carefully. To avoid damaging the points, do not touch them with hard objects such as a screwdriver.

To insert the new emitter points, hold the 980 Ionized Air Gun with the barrel pointing up.

Grasp the new clip between your thumb and forefinger, and align it so the curved edges match the curve of the inside of the 980 Ionized Air Gun barrel.

Align the blunt prongs of the emitters with the holes in the SCS 980 Ionized Air Gun barrel and set the clip into place.

Press the clip all the way in using the tip of a screwdriver. It should fit snugly between the raised rim of the barrel and the raised rim of the air nozzle. If the clip overlaps the air nozzle, it is installed backward.

The below table lists the replacement parts and optional parts available for the SCS 980/980E Ionized Air Gun.

Part	Item	Status
120VAC Wall Transformer	960X/980X	Replacement
230VAC Wall Transformer	980E-X	Replacement
Air Filter 3-Pack	980-F	Replacement
Foot Switch	980-S	Optional
Emitter Points	980-T	Replacement

Testing for Proper Operation

To make sure that your SCS 980 Ionized Air Gun is working properly, check the balance and discharge levels. The performance of the unit should be measured periodically using a charged plate monitor, such as SCS items 711, 770004 and 770005.

Calibration should be performed in accordance with the ESD Association ionization standard ANSI/ESD-S3.1. At a line pressure of 30 psi (2 bars), discharge of ± 1000 volts to ± 100 volts should require less than 1 second at a distance of 6 inches (15 cm) and balance should be within ± 30 volts of zero.

Specifications

General

Audible Noise	73dBA @ 1 meter, 30 psi (2bars) pressure to air gun
Ozone	<0.005 ppm (24-hour accumulation)
Certifications	cULus for Ionized Air Gun 980 CE for Ionized Air Gun 980E

Hand Unit

Construction	Static-dissipative polycarbonate
Ion Emission	Steady-state DC
Emitter Points	Tungsten alloy
Ion Indicator	Green LED
Air Hose	7' (2.1m) length, 3/8" (0.96 cm) outside diameter of static dissipative polyurethane
Gun Hanger	#302 stainless steel
Dimensions	8.0" L x 3.0" W x 1.0" D (20.3 cm L x 7.6 cm W x 2.5 cm D)
Weight	12.0 oz. (341 g) with 7' (2.1 m) air hose

Console

Construction	Static-dissipative polycarbonate
Input Power	24VAC, <10 Watts, powered from transformer

Power	Indicator Green LED
Air/Gas Input	20-65 PSI (1.4 - 4.5 bars), clean dry air or nitrogen. For safety purposes, this unit has been tested at 1.5 times these air pressures.
Air/Gas Connection	1/4" (0.64 cm) male US-industrial interchange quick disconnect and 1/4" (0.64 cm) NPT female coupler
Air Filter Mounting	99.9% efficient, 0.1 micron or larger Metal mounting plate attaches to back of the unit
Dimensions	8.5" L x 3.0" W x 1.6" D (21.6 cm L x 7.6 cm W x 4.1 cm D)
Weight	11.5 oz. (326 g)

Transformer

Input	980: 120VAC (960/980X) 60 Hz 410A 980E: 230VAC (980E-X) 50 Hz 250mA
Output Power	24VAC, 1670 mA
Cabling	10' (3 m) cable with RJ-11 connectors (from power supply transformer)
Dimensions	8" H x 8" W x 2.3" D (203.2 mm H x 203.2 mm W x 58.42 mm D)
Weight	4 lbs.
Certifications	cULus, RoHS, RoHS (China) (120VAC model) CE, RoHS, RoHS (China) (230VAC model)

Packaging

- 1 - Air Gun
- 1 - Console
- 1 - Air Hose
- 1 - Power Supply
- 1 - User's Guide

Regulatory Information



This symbol, per “Marking for the Control of Pollution Caused by Electronic Information Products, SJ/T11364-2006,” means that the product or part does not contain any substances in excess of the maximum concentration values as per “Electronic Industry Standard

of the People’s Republic of China, SJ/T11363-2006, Requirements for Concentration Limits for Certain Hazardous Substances in Electronic Information Products.” This information represents SCS’s knowledge and belief, which may be based in whole or in part upon information provided by third party suppliers to SCS. In the event any product is proven not to conform with the material content-related information in this product literature, then SCS’s entire liability and Buyer’s exclusive remedy will be in accordance with the Warranty stated below. e-Waste Disposal-Recycle according to applicable local, state and federal laws for electrical/electronic waste.

RoHS 2011/65/EU Compliant means that the product or part does not contain any of the substances in excess of the maximum concentration values (“MCVs”) in EU RoHS Directive 2011/65/EU. The MCVs are by weight in homogeneous materials. This information represents SCS’s knowledge and belief, which may be based in whole or in part on information provided by third party suppliers to SCS.

WEEE Statement

The following information is only for EU-member States: The mark shown to the right is in compliance with Waste Electrical and Electronic Equipment Directive 2002/96/EC (WEEE). The mark indicates the requirement NOT to dispose the equipment as unsorted municipal waste, but use the return and collection systems according to local law.

cULus Statement

Meets cULus requirements.

CE Statement

ElectroMagnetic Compatibility Statement: Meets 2004-108-EC Directive.
Low Voltage: Meets 2006-95-EC Directive.

Limited Warranty, Warranty Exclusions, Limit of Liability and RMA Request Instructions